

binder+cō

bivitec

Difficult-to-screen bulk materials and highest levels of separation



we process the future



Processing Technology



TASK

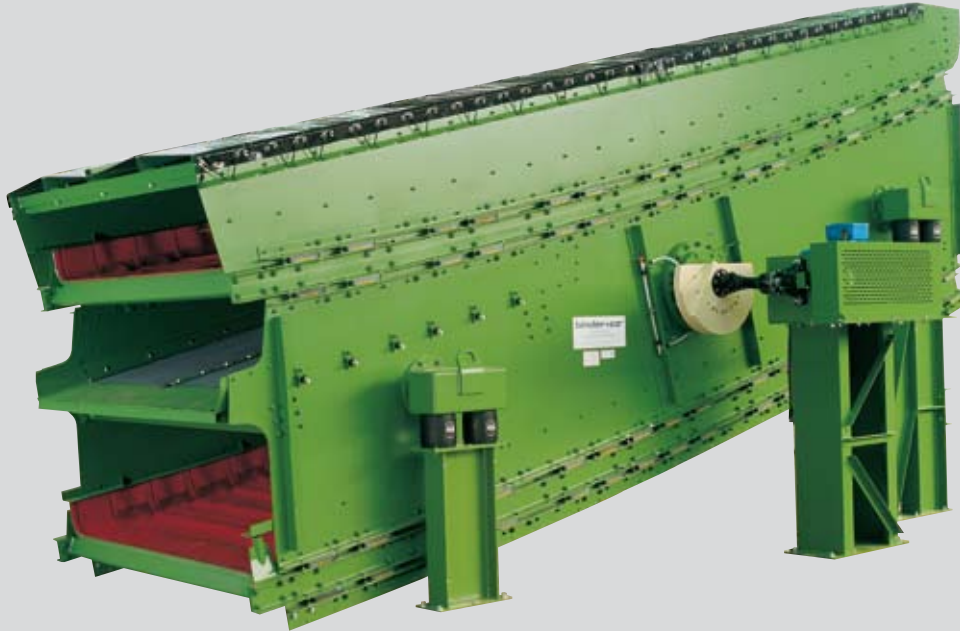

In processing technology, it is increasingly a question of classifying raw materials and intermediate products. This places considerable problems on such conventional screening machines as circular vibratory screens and linear vibratory screens.

Three main reasons are responsible for this:

- The high material humidity in connection with clay, mud or other impurities causes a build-up on the screen surface
- Fingery as well as bladed material leads to the development of sticking grain
- Fibrous, matted substances entangle the screen webs

Result: In all the three cases, no screening can take place any longer because the screen surface is blocked.

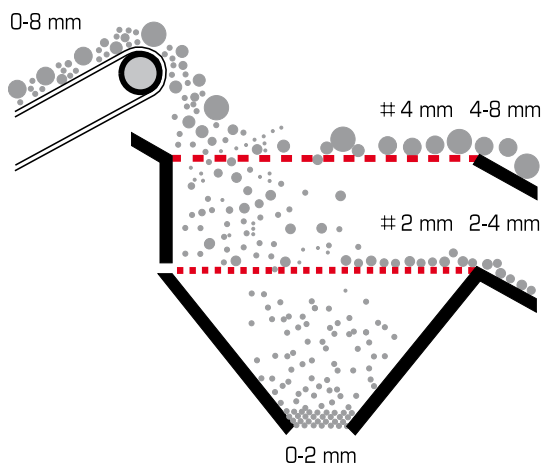

Material with a high surface humidity, e. g.:

Clayey sand



Dolomite



Splintery and fingery material, e. g.:

Basaltes



Plastic chips



Clotted substances, e. g.:

Mixed debris



Peat



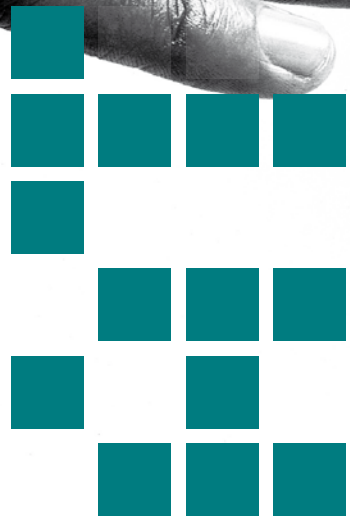



SOLUTION

In order to ensure the screening function, the acceleration values to be made to act on the screening material that is difficult to screen are much higher than usually. For optimally fulfilling this task, Binder+Co has developed a solution that is both simple and efficient: BIVITEC screening machines with a dual vibration principle from a single drive. The development of the BIVITEC screening machines was based upon the conventional circular vibratory screen. This screen is the body describing the fundamental mode even today. The linear vibratory screen represents an advance as a basic screen for larger overall lengths. The special feature of BIVITEC screening machines is the dual vibration principle. With the aid of resonance, one drive provides two vibration movements. In this process, high acceleration rates are achieved by expanding and contracting the dynamic screening mats. In order to achieve a maximum life cycle, the high-quality screen mats made of polyurethane are not to be operated at a constantly high expansion, but with an expansion adapted to the material to be screened.

FUNCTION

At BIVITEC screening machines, a functional solution that is just as simple as intelligent guarantees free screen surfaces and thus best performance. Two weights vibrating with the same frequency describe a relative motion to each other and untension or tension the screening mats. In this context, the linear momentum of both vibrating weights is adjustable and thus ensures an optimal operation of the machine. The respective parameters can be adapted individually to the screening material before each operation.

DRIVE

The drive is provided by an electric motor, a V-belt drive, a cardan shaft and a shaft with adjustable unbalanced weights. The fundamental oscillation only requires a low driving power.





TECHNOLOGY

The dual vibration principle of BIVITEC screening machines results from a fundamental oscillation and an overlaid vibration. The fundamental oscillation describes a circular or linear motion, which is introduced by a circular or linear vibratory screen. The overlaid vibration describes an elliptic motion and is started by the fundamental oscillation.

The Bearings

The screening machine is bedded on hollow springs made of rubber, because the following advantages won't be provided by helical springs:

- Hollow springs made of rubber cause little noise
- have optimal inlet and outlet properties
- provide a high life cycle

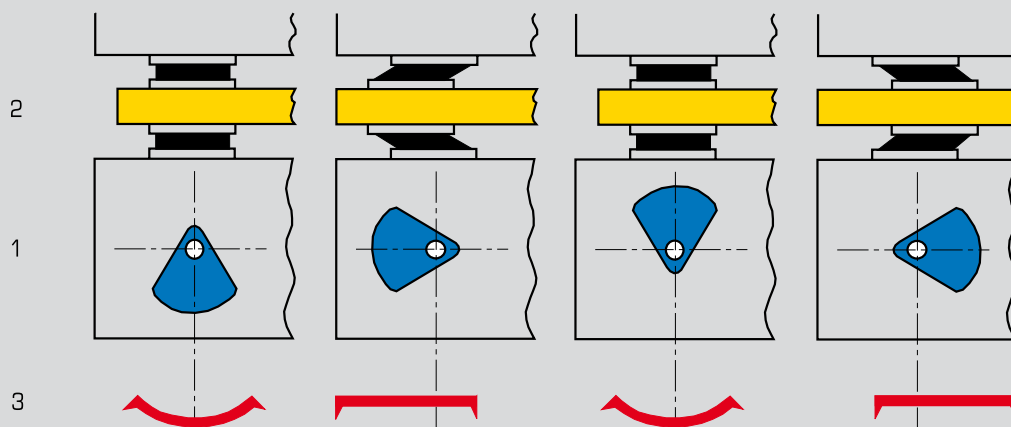

- | | |
|-------------------------|--|
| 1 - Vibrating weight 1: | circular amplitudes adjustable $2a = 4-7\text{mm}$ |
| 2 - Vibrating weight 2: | ellipse $2a = 12-18\text{ mm}$ |
| 3 - Screenmat: | expansion or contraction |



QUALITY IN USE

Practical

BIVITEC screening machines are designed for screen cuts of 0.2 – 50 mm. The fact that the screen mats are fixed without screws guarantees a gentle screening as well as a fast change of the screen mats and prevents caking. For changing a screening area of 10 m², about one working hour is required.

Efficient

The descending gradients of the screening machine that are selected are low in order to ensure that particles frequently hit the screen mats and therefore an optimal screening performance can be achieved. The lateral OX-HORN designed seal prevents outside rejection and minimises wear.

Economical

The energy applied to the charging material by the screening mats excited dynamically and the fundamental oscillation is not higher than is required for loosening up the screening material and for keeping the screen liners open. Furthermore, the simple and proven drive guarantees minimum maintenance expenditure.





PERFORMANCE

BIVITEC screening machine

1. Material Data

Feeding capacity up to 1000 t/h

Grain size up to 80 mm (bulk density $> 1.5 \text{ t/m}^3$)
up to 200 mm (bulk density $< 1.5 \text{ t/m}^3$)

Screen cuts of 0.2 – 70 mm

2. Machine Data

Screen widths, fully usable from 400 mm to 3000 mm

Screen lengths, fully usable from 2 m to 12 m

Machine weights from 1 ton to 25 tons

Driving power from 2 kW to 55 kW

Descending gradient of the screens from 5 degrees
to 24 degrees



DESIGNS

BIVITEC screening machines are available as single deck screens, double deck screens or single deck screens with a rigid protective deck.

The banana BIVITEC offers the ideal solution for the screening of materials difficult to screen with a high fine grain content in the charging material and when carrying out two cut points per screen deck.

It combines the advantages of banana screens with those of the BIVITEC:

- A constant radius of curvature prevents erratic transitions from steep to plain screen deck inclinations
- High material velocities on the screen deck on the feeding side and relatively low layer heights allow for considerably higher specific throughput rates
- An improved whole grain separation is achieved by significantly lower material velocities and therefore a higher time of stay and layer formation on the discharge end of the screen deck



- Processing Technology
- Environmental Technology
- Bagging Technology

Binder+Co AG, Grazer Strasse 19-25, A-8200 Gleisdorf, Austria
Tel.: +43-3112-800-0*, Fax: +43-3112-800-398
e-mail: at@binder-co.at
www.binder-co.com

2008

The know-how Binder+Co boasts in the processing of bulk material and recycling material is reflected in a large range of special machinery, which is used for raw material, building and chemical industries worldwide. Furthermore, the company delivers turnkey solutions – from planning via design, production and assembly to commissioning.

Highly qualified employees convert metal to intelligent machines and structures. The most important strong point of the Austrian company is its 50 years' experience in preparing tailored solutions for specific customer needs.

A large range of solutions that are superior in terms of technology and the considerable know-how in screening bulk material allow Binder+Co to use the appropriate screening machine for each material. Besides the classical linear, circular and resonance vibratory screens, the special screen BIVITEC fulfills the tasks that are particularly delicate.

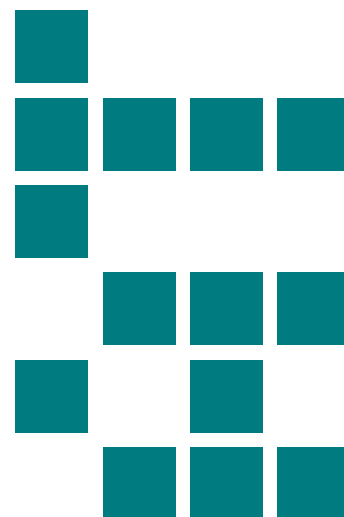

Processing Technology